

Malzeme / Material : Alüminyum Almg3 / Aluminium Almg3

Ölçülendirme / Dimensions								Kuvvet / Forces	Ürün / Product
Çap Diameter	Boy Length	Kafa Çapı Head Diameter	Pim Çapı Pin Diameter	Pim Boyu Pin Length	Kafa Altı Under Head	Kafa Kalınlığı Head Thickness	Açı Angle	Çelik / Steel 4.8 ¹⁾ R _{p0.2} = 340 N/mm ²	
d ₁	l ₁ +0.6	d ₂ ±0.2	d ₄ ±0.08	l ₃ ±0.05	max. h ₅	h ₁	α ±2°	Kesme Torku (Nm) Shearing Torque (Nm)	
M3	6.0	4.50	0.60	0.55	0.60	0.70 - 1.40	174°	0.5	03.01PT01.M0306
	8.0								03.01PT01.M0308
	10.0								03.01PT01.M0310
	12.0								03.01PT01.M0312
	15.0								03.01PT01.M0315
	16.0								03.01PT01.M0316
	20.0								03.01PT01.M0320
	25.0								03.01PT01.M0325
	30.0								03.01PT01.M0330
	35.0								03.01PT01.M0335
	40.0								03.01PT01.M0340
	45.0								03.01PT01.M0345
	50.0								03.01PT01.M0350

* DIN EN ISO 13918'e uygundur. / Similar to DIN EN ISO 13918.

* Tüm ölçüler mm cinsindedir. / All dimensions in mm

* Tüm boy ölçülerinde [+0,1/-0,5] mm tolerans değeri olasıdır. / A tolerance value of [+0,1/-0,5] mm is possible for all length dimensions.

* Ölçü standardı M3 ve M8 arasındadır (M10 için özel imalat gerekir) / Size standard is between M3 and M8 (M10 With modification only)

* Uygulama videosu için QR kodu okutun. / Scan the QR code for the application video.



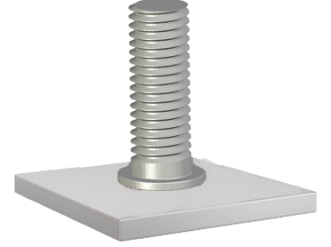
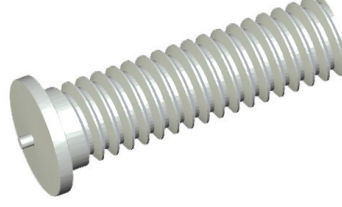
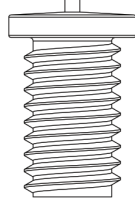
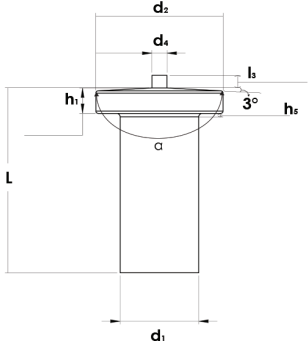

Malzeme / Material : Alüminyum Almg3 / Aluminium Almg3

Ölçülendirme / Dimensions								Kuvvet / Forces	Ürün / Product
Çap Diameter	Boy Length	Kafa Çapı Head Diameter	Pim Çapı Pin Diameter	Pim Boyu Pin Length	Kafa Altı Under Head	Kafa Kalınlığı Head Thickness	Açı Angle	Çelik / Steel 4.8 ¹⁾ R _{p0.2} = 340 N/mm ²	
d ₁	l ₁ +0.6	d ₂ ±0.2	d ₃ ±0.08	l ₃ ±0.05	max. h ₅	h ₁	α ±2°	Kesme Torku (Nm) Shearing Torque (Nm)	
M4	6.0	5.50	0.65	0.55	0.60	0.70 - 1.40	174°	0.6	03.01PT01.M0406
	8.0								03.01PT01.M0408
	10.0								03.01PT01.M0410
	12.0								03.01PT01.M0412
	15.0								03.01PT01.M0415
	16.0								03.01PT01.M0416
	20.0								03.01PT01.M0420
	25.0								03.01PT01.M0425
	30.0								03.01PT01.M0430
	35.0								03.01PT01.M0435
	40.0								03.01PT01.M0440
	45.0								03.01PT01.M0445
	50.0								03.01PT01.M0450

* DIN EN ISO 13918'e uygundur. / Similar to DIN EN ISO 13918.

* Tüm ölçüler mm cinsindedir. / All dimensions in mm

* Tüm boy ölçülerinde [+0,1/-0,5] mm tolerans değeri olasıdır. / A tolerance value of [+0,1/-0,5] mm is possible for all length dimensions.

* Ölçü standardı M3 ve M8 arasındır (M10 için özel imalat gerekir) / Size standard is between M3 and M8 (M10 With modification only)

* Uygulama videosu için QR kodu okutun. / Scan the QR code for the application video.



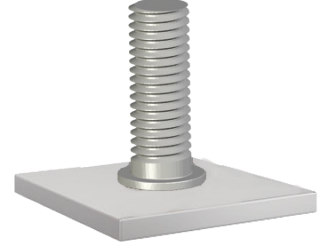
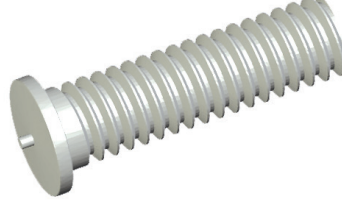
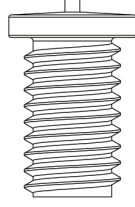
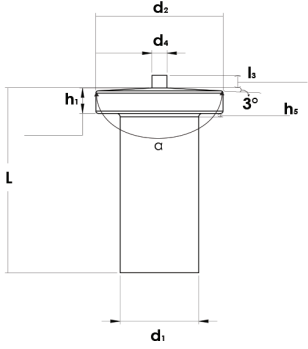

Malzeme / Material : Alüminyum Almg3 / Aluminium Almg3

Ölçülendirme / Dimensions								Kuvvet / Forces	Ürün / Product
Çap Diameter	Boy Length	Kafa Çapı Head Diameter	Pim Çapı Pin Diameter	Pim Boyu Pin Length	Kafa Altı Under Head	Kafa Kalınlığı Head Thickness	Açı Angle	Çelik / Steel 4.8 ¹⁾ R _{p0.2} = 340 N/mm ²	 03.01PT01
d ₁	l ₁ +0.6	d ₂ ±0.2	d ₃ ±0.08	l ₃ ±0.05	max. h ₅	h ₁	α ±2°	Kesme Torku (Nm) Shearing Torque (Nm)	
M5	6.0	6.50	0.75	0.80	1.00	0.70 - 1.40	174°	1.1	03.01PT01.M0506
	8.0								03.01PT01.M0508
	10.0								03.01PT01.M0510
	12.0								03.01PT01.M0512
	15.0								03.01PT01.M0515
	16.0								03.01PT01.M0516
	20.0								03.01PT01.M0520
	25.0								03.01PT01.M0525
	30.0								03.01PT01.M0530
	35.0								03.01PT01.M0535
	40.0								03.01PT01.M0540
	45.0								03.01PT01.M0545
	50.0								03.01PT01.M0550

* DIN EN ISO 13918'e uygundur. / Similar to DIN EN ISO 13918.

* Tüm ölçüler mm cinsindedir. / All dimensions in mm

* Tüm boy ölçülerinde [+0,1/-0,5] mm tolerans değeri olasıdır. / A tolerance value of [+0,1/-0,5] mm is possible for all length dimensions.

* Ölçü standardı M3 ve M8 arasındır (M10 için özel imalat gerekir) / Size standard is between M3 and M8 (M10 With modification only)

* Uygulama videosu için QR kodu okutun. / Scan the QR code for the application video.



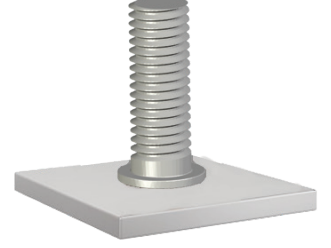
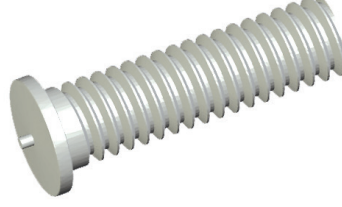
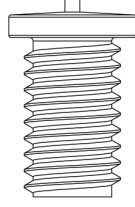
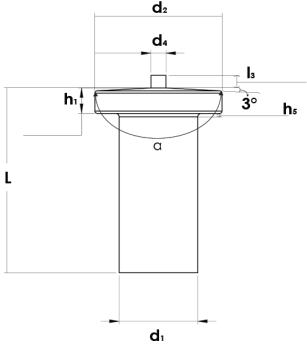

Malzeme / Material : Alüminyum Almg3 / Aluminium Almg3

Ölçülendirme / Dimensions								Kuvvet / Forces	Ürün / Product
Çap Diameter	Boy Lenght	Kafa Çapı Head Diameter	Pim Çapı Pin Diameter	Pim Boyu Pin Lenght	Kafa Altı Under Head	Kafa Kalınlığı Head Thickness	Açı Angle	Çelik / Steel 4.8 ¹⁾ R _{p0.2} = 340 N/mm ²	
d ₁	l ₁ +0.6	d ₂ ±0.2	d ₃ ±0.08	l ₃ ±0.05	max. h ₅	h ₁	α ±2°	Kesme Torku (Nm) Shearing Torque (Nm)	
M6	6.0	7.50	0.75	0.80	1.00	0.70 - 1.40	174°	2.0	03.01PT01.M0606
	8.0								03.01PT01.M0608
	10.0								03.01PT01.M0610
	12.0								03.01PT01.M0612
	15.0								03.01PT01.M0615
	16.0								03.01PT01.M0616
	20.0								03.01PT01.M0620
	25.0								03.01PT01.M0625
	30.0								03.01PT01.M0630
	35.0								03.01PT01.M0635
	40.0								03.01PT01.M0640
	45.0								03.01PT01.M0645
	50.0								03.01PT01.M0650

* DIN EN ISO 13918'e uygundur. / Similar to DIN EN ISO 13918.

* Tüm ölçüler mm cinsindedir. / All dimensions in mm

* Tüm boy ölçülerinde [+0,1/-0,5] mm tolerans değeri olasıdır. / A tolerance value of [+0,1/-0,5] mm is possible for all length dimensions.

* Ölçü standardı M3 ve M8 arasındır (M10 için özel imalat gerekir) / Size standard is between M3 and M8 (M10 With modification only)

* Uygulama videosu için QR kodu okutun. / Scan the QR code for the application video.



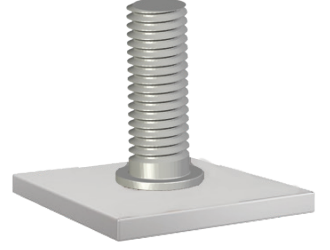
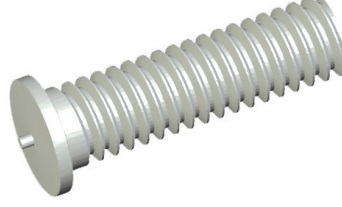
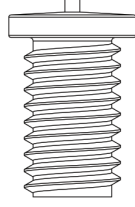
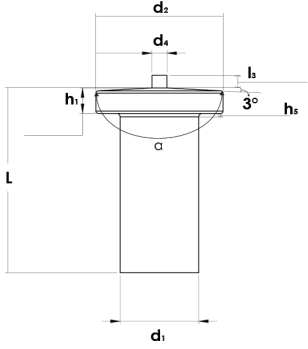

Malzeme / Material : Alüminyum Almg3 / Aluminium Almg3

Ölçülendirme / Dimensions								Kuvvet / Forces	Ürün / Product
Çap Diameter	Boy Lenght	Kafa Çapı Head Diameter	Pim Çapı Pin Diameter	Pim Boyu Pin Lenght	Kafa Altı Under Head	Kafa Kalınlığı Head Thickness	Açı Angle	Çelik / Steel 4.8 ¹⁾ R _{p0.2} = 340 N/mm ²	
d ₁	l ₁ +0.6	d ₂ ±0.2	d ₄ ±0.08	l ₃ ±0.05	max. h ₅	h ₁	α ±2°	Kesme Torku (Nm) Shearing Torque (Nm)	
M8	6.0	9.00	0.75	0.85	1.50	0.80 - 1.40	174°	4.7	03.01PT01.M0806
	8.0								03.01PT01.M0808
	10.0								03.01PT01.M0810
	12.0								03.01PT01.M0812
	15.0								03.01PT01.M0815
	16.0								03.01PT01.M0816
	20.0								03.01PT01.M0820
	25.0								03.01PT01.M0825
	30.0								03.01PT01.M0830
	35.0								03.01PT01.M0835
	40.0								03.01PT01.M0840
	45.0								03.01PT01.M0845
	50.0								03.01PT01.M0850

* DIN EN ISO 13918'e uygundur. / Similar to DIN EN ISO 13918.

* Tüm ölçüler mm cinsindedir. / All dimensions in mm

* Tüm boy ölçülerinde [+0,1/-0,5] mm tolerans değeri olasıdır. / A tolerance value of [+0,1/-0,5] mm is possible for all length dimensions.

* Ölçü standardı M3 ve M8 arasındır (M10 için özel imalat gerekir) / Size standard is between M3 and M8 (M10 With modification only)

* Uygulama videosu için QR kodu okutun. / Scan the QR code for the application video.

